



ACTIVE TRAVEL STRATEGY

2021 - 2031



LIVE
LEARN
WORK
INVEST
VISIT

Contents

Section	Page
Foreword	03
Introduction.....	04
Developing the Strategy	05
Vision & Objectives	08
Targets	11
Transport Context	12
Future Network Vision.....	15
Action Plan	21
Appendices	22

Foreword

Welcome to this Active Travel Strategy for North Lanarkshire which sets out our approach to active travel policy in our area for the next 10 years.

In North Lanarkshire, and Scotland as a whole, there is continuing drive to create a sustainable transport system. This system should recognise the challenges before us, particularly in terms of reducing inequalities and taking climate action. To this end, the Council is fully engaged in responding to the global climate emergency by supporting increasing mode shift toward low and zero carbon transportation.

The development of this new strategy is timely, not least because these challenges have been furthered by the need to continue to adapt to life after COVID-19. This may bring permanent changes to the way people will live, work and travel around our area. Therefore, the Council needs to provide a targeted approach to enhancing the provision of active and sustainable travel opportunities. This will then support a mode shift in favour of walking, wheeling and cycling.

This strategy complements extensive work undertaken by the Council between 2018 and 2020 which focussed on identifying specific transport interventions in Airdrie, Bellshill, Coatbridge, Croy, Cumbernauld, Harthill, Kilsyth, Motherwell, Salsburgh, Shotts and Wishaw. This previous work was supported by

extensive public and stakeholder consultation which identified the range of problems, issues, constraints and opportunities on our transport network. This has led to development of specific actions that we will be seeking to bring forward as this strategy is implemented in the coming years.

Significantly, the strategy provides a framework for this Council to prioritise and bring forward active travel interventions across North Lanarkshire which will improve links within our towns. These will align with our Town Visions to provide better active travel networks between our communities and across our local authority boundary. This will ensure, that the possibilities afforded by the strategy are not just confined to journeys made within North Lanarkshire. The strategy places a strong emphasis on strengthening wider strategic connections with our neighbouring authorities, as well as links with partner and stakeholder groups, both corporate and community based.

By adopting this strategy, the Council is making a statement of intent that we will have in place a framework for active travel that supports integration

in our transport network. This will help to deliver improved health and well-being and environmental, social inclusion and public access benefits.

The approach we are taking to improve the long-term uptake of walking and cycling in North Lanarkshire supports the Scottish Government's National Transport Strategy and Active Travel Framework which incorporate the aims of the National Walking Strategy and Cycling Action Plan. Through the strategy, the Council will provide local support to a national commitment to make our journeys more sustainable. It will also improve the adaptability of our transport network to the future challenges we are all facing.



Councillor Michael McPake
**Convener, Environment and
Transportation Committee**

Introduction

This strategy aims to create a wide range of connections across North Lanarkshire which can be utilised for everyday journeys such as travelling to access employment, education or meeting essential needs in addition to recreational purposes.

What is Active Travel?

Active Travel is a means of transportation which is undertaken by physical activity without the use of motorised vehicles. Active travel can take many forms but primarily consists of walking, wheeling and cycling.

Why do we need an Active Travel Strategy?

By providing suitable infrastructure and facilities to support the uptake of active travel, we can reduce reliance on the private car; thereby reducing carbon emissions and improving overall health and well-being.

This strategy allows key strategic and local connections to be identified to improve walking, wheeling and cycling facilities across our area. By identifying missing active travel links at a local level, we can seek to improve connections and create '20 minute neighbourhoods.' These 20 minute neighbourhoods will allow our communities to reach the majority of their essential needs within a 20 minute walk of their home.

In addition, there is now a growing understanding of the impacts and the potential spread of transport poverty. This is often defined as where a lack of access to good-quality and affordable transport options contributes to preventing people from accessing essential needs, employment, services, education or training. Improving accessibility with high quality active travel connections can help combat the potential impacts of transport poverty by providing accessible, alternative and low-cost transport options.



Developing the Strategy

Initial steps towards the development of this strategy were taken by the Council in 2018 when our first sustainable transport study was completed. This earlier work assessed transport problems and opportunities in Airdrie and Coatbridge and set out a detailed action plan for improvements, particularly those focussed on active travel.

Subsequent sustainable transport studies were completed between 2019 and 2020 for Bellshill, Croy, Cumbernauld, Harthill, Kilsyth, Motherwell, Salsburgh, Shotts and Wishaw. These set out further action plans for walking, wheeling, and cycling infrastructure improvements and promotion of behavioural change. These studies have laid the foundation for the Council to now progress with a strategy for active travel across our area.

The progression of the sustainable transport studies has facilitated identification of common active travel related problems, issues, constraints and opportunities across North Lanarkshire. These are shown in Figure 1.

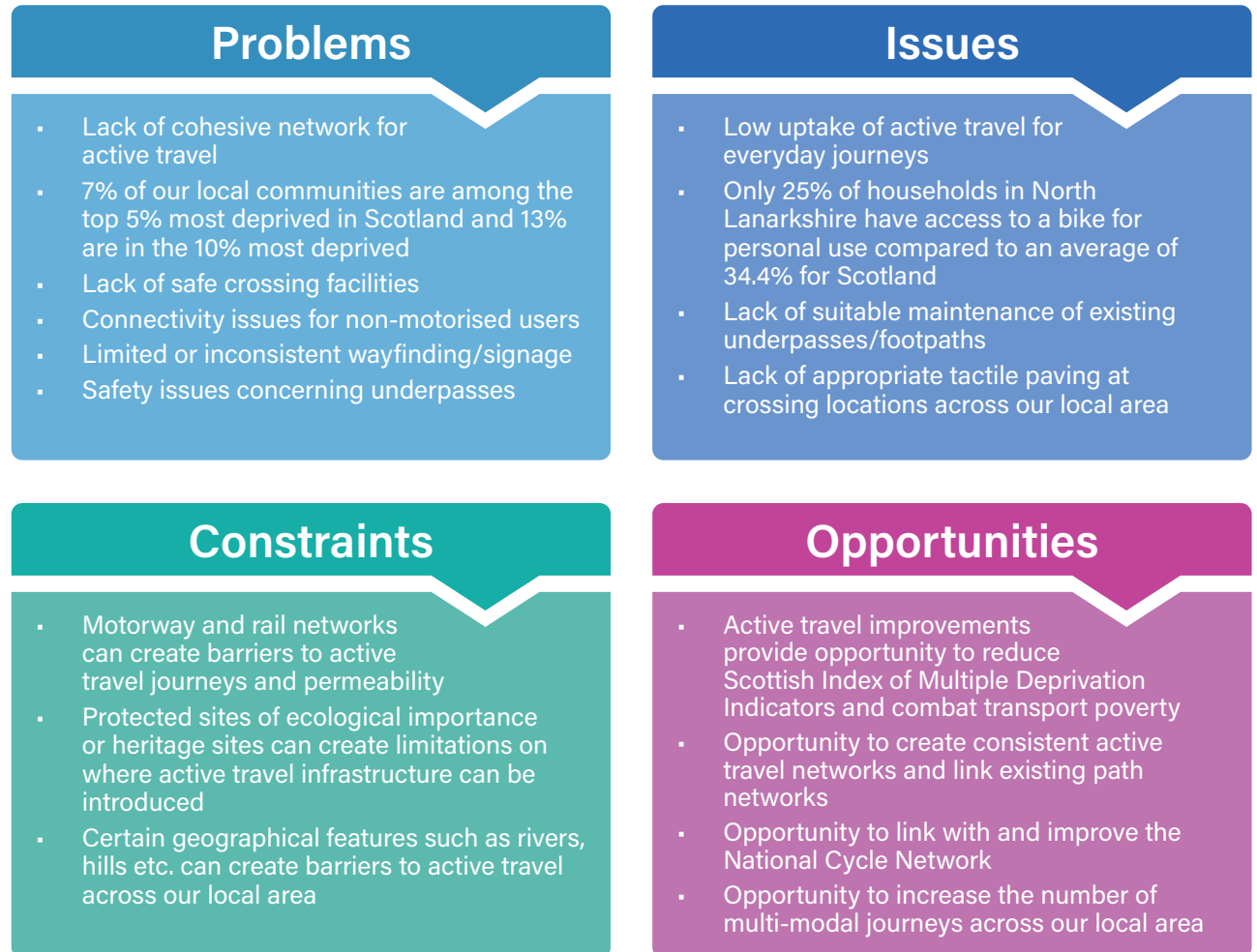

Figure 1 - Problems, Issues, Constraints and Opportunities

Strategy development and partners

The development of this strategy has been supported by collaborative discussions with organisations that have a role in promoting active travel in our area and with our neighbouring authorities.

With extensive public and stakeholder engagement undertaken between 2018 and spring 2020 to support the sustainable transport studies, the Active Travel Strategy is built on a foundation of consultation. This has captured the key issues and opportunities we need to consider to make active travel a viable and alternative mode for travelling within (and to and from) North Lanarkshire.

It is important that the Active Travel Strategy provides a framework for the delivery of actions and potential projects identified in the individual sustainable transport studies. The strategy must take consideration of commuter, leisure/recreational and cross-boundary links to our neighbouring authorities. The strategy will also help to enable the delivery of local policies across North Lanarkshire.

Key partners such as the Green Network Trust are currently undertaking work both locally and regionally on the Glasgow and the Clyde Valley Green Network Blueprint; part of a much wider Central Scotland Green Network. The Blueprint is a framework for the creation of:

- A **Strategic Green Network** - facilitating the off-road movement of people around and between communities through Green Active Travel routes and greenspace; and
- A **Strategic Habitat Network** - facilitating the movement of wildlife through the landscape



Figure 2 - North Lanarkshire and neighbouring collaborators map

Policy and strategy context

The development of this strategy has been influenced by the various Local, Regional and National strategies and policies which influence transport within North Lanarkshire. Further information on these can be found in Appendix A.

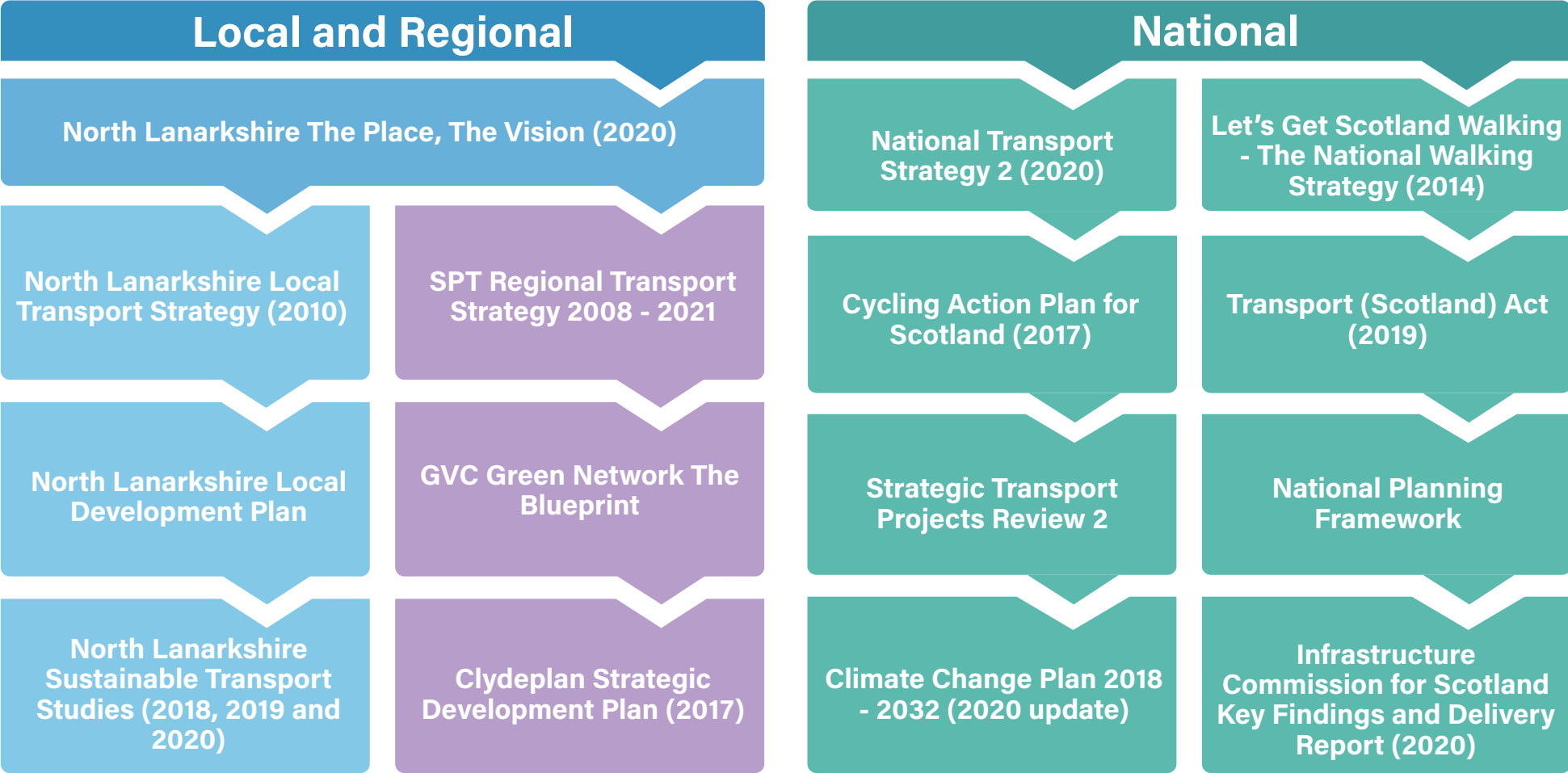

Figure 3 - Policy and Strategy Context Diagram

Vision & Objectives

This strategy has a vision that:

North Lanarkshire has a high quality, accessible active travel network which supports the well-being of our residents and visitors, enhances social inclusion and improves the ability of people to walk, wheel or cycle for any journey purpose in our area.

To realise this vision, the strategy will:

- Deliver greater priority to active modes of travel in North Lanarkshire by improving and enhancing our walking, wheeling and cycling network and making it easier to travel around our area sustainably
- Deliver better Strategic, Local Neighbourhood and Connecting Active Travel Networks across North Lanarkshire that support our Town Visions, improve sense of place and contribute to making our communities vibrant and sustainable
- Deliver active travel interventions in North Lanarkshire that complement and facilitate major transport and development projects in our area, including our Town and Community Hubs and facilitate access to business, industry and strategic employment locations
- Implement and maintain an active travel network which supports improved quality of life, health and well-being across North Lanarkshire
- Improve safety and perceptions of safety for those travelling by active modes to, from and within North Lanarkshire
- Deliver active travel interventions in North Lanarkshire which provide support for wider initiatives aimed at enhancing integration between walking, wheeling, cycling links and public transport hubs
- Deliver active travel interventions in North Lanarkshire that facilitate enhancement of cross-boundary links to neighbouring areas including Glasgow, South Lanarkshire, West Lothian and East Dunbartonshire



The Place, The Vision

This is North Lanarkshire. The place to **Live, Learn, Work, Invest** and **Visit**.

The Place, The Vision is our plan for North Lanarkshire, for our businesses and our people, boosting the local economy and creating jobs. This plan outlines a programme of place-based investment that aims to address the range of different economic, social and health issues that exist at a local level to achieve a change that is sustainable in the longer-term. Together, the Town Visions, Country Parks for the Future and Town and Community Hubs programmes seek to create a coherent, vibrant and sustainable future for North Lanarkshire.

Country Parks of the Future

The plan recognises the role greenspace has and includes a series of masterplans for the following country parks: Palacerigg Country Park, Drumpellier Country Park and Strathclyde Country Park. Country Parks and greenspace provide opportunities to form key active travel hubs and improve health.



Country Parks of the Future

Town Visions

Town centres have been challenged by the rise of online and out-of-town shopping. To address the difficulties towns face and to avoid dereliction and further decline, the answer is to reposition town centres as mixed-use spaces, promoting town centre living and putting staff and services closer to communities. There will be a much stronger focus on new-build housing, residential conversion and refurbishment. Each of the eight towns in North Lanarkshire have their own challenges, opportunities, history and heritage so this will not be a one size fits all exercise. These Visions represent a long-term strategy for transformation over a 15-20 year period.



Cumbernauld Town Vision

Town and Community Hubs

Schools are the heart of towns and communities and represent the biggest investment in infrastructure across North Lanarkshire. The Council has a commitment to replace every school not replaced or remodelled since 1996 and a vision to make these places for the whole community.

To do this, three types of hubs have been envisaged:

- Town hubs are likely to include primary and secondary education and an early years' facility. Other services such as comprehensive sport, culture and leisure facilities will be offered on a larger scale.
- Community hubs are likely to include at least one learning establishment and may include other facilities such as sport and leisure.
- Small community hubs may exist in areas where there is not requirement for new education facilities but where there is a need to replace older facilities like libraries, community centres and health centres.

Proposed Hub Locations include:

- **Airdrie:** Monklands Hospital / Rawyards
- **Bellshill:** Hattonrigg Road / Bellshill Academy and Sports Fields / Cardinal Newman High School and Sir Matt Busby Sports Complex
- **Coatbridge:** St Ambrose High School / Coatbridge High School / St Andrews High School
- **Cumbernauld:** Our Lady's High School / Cumbernauld Town Centre
- **Kilsyth:** Kilsyth Academy / Town Centre
- **Motherwell:** Forgewood / North Motherwell / Ravenscraig
- **Shotts:** Calderhead High School
- **Wishaw:** St Aiden's High School / Wishaw Sports Centre



Figure 4 - Town and Community Hub Principles

Targets

Each year, we will prepare an Annual Monitoring Report to allow progress against the implementation of the Active Travel Strategy Action Plan to be assessed. This will help to keep us on track and in line with the National Transport Strategy's sustainable transport priorities.

Key strategy targets include:

- ▶ Increasing the number of journeys to work using active travel means
- ▶ Increasing the number of cycle parking spaces at local amenities, key employment centres, transport links and Town and Community hubs
- ▶ Introducing additional walking, wheeling and cycling connections to provide links to key destinations and local community hubs
- ▶ Encouraging the uptake of schemes associated with active travel
- ▶ Increasing the number of directional/wayfinding signs to aid people to reach their destinations
- ▶ Targeted improvements to active travel in areas with recognised issues on the list of Scottish Index of Multiple Deprivation indicators and combating potential transport poverty

Prioritising Sustainable Transport

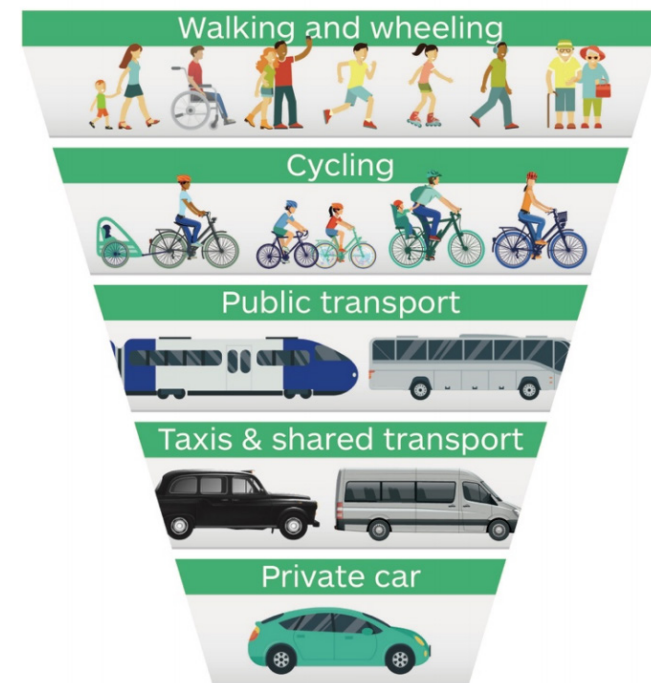

Figure 5 - Sustainable Transport Hierarchy (Source: National Transport Strategy)

Transport Context

This strategy seeks to redress some of the historic transport network imbalance across North Lanarkshire away from the private car and towards active travel.

Around 13% of Scotland's motorway network is located in North Lanarkshire, with the M73, M74, M8 and M80 providing strategic links for the private car and some bus services around and beyond North Lanarkshire. In addition, there are various rail lines linking the towns and wider destinations, including the wider Central Scotland urban rail network. Much of the existing transport network benefits those with access to a car, but can present challenges or create a significant barriers to those without access to a private car.

Data from Transport Scotland's Transport and Travel in Scotland Report 2019 shows that many of the journeys undertaken within North Lanarkshire are under 5km. This high percentage of trips under 5km indicates a great potential for increasing modal shift to travel by walking, wheeling or cycling. Currently, 31% of households across North Lanarkshire have no access to a car for private use. It is essential that active travel options are accessible, attractive and affordable to reach services, employment, education and training opportunities across our area.

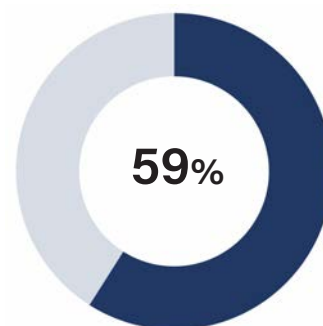

Proportion of journeys under 5km

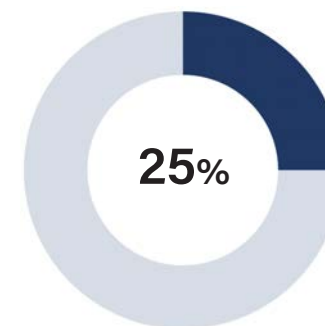

Households with access to one or more bikes for private use

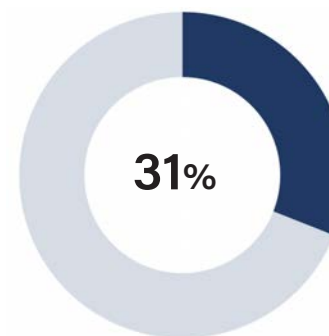

Households with no access to a car for private use

Figure 6 - Transport and Travel in Scotland Report 2019 (Transport Scotland)

Existing Active Travel Network

North Lanarkshire currently has a wide range of both on-road and off-road walking, wheeling and cycling facilities that make up the existing active travel network with a great mix of routes for everyday and leisure use. The existing network consists of dedicated on-road cycle lanes, off-road shared use walking, wheeling and cycling routes, simple footways and footpaths, low traffic speed or volume cycle-friendly streets and quiet rural roads. There is also a great network of public paths owned or managed by third parties or other organisations both within and connecting beyond North Lanarkshire.

SMARTways was a council initiative which aimed to promote more sustainable modes of transportation within our area such as walking, cycling, public transport and car sharing. The SMARTways map provided information to users about local off-road walking and cycling routes, on-road cycling and other routes to encourage the local community to change how they travel. The routes previously identified by SMARTways have been incorporated into this strategy and will be used to highlight and improve local connections.

Some of the most significant routes in the existing local active travel network include the following on-road and off-road routes:

- National Cycle Route 75 (NCN 75)
- North Calder Heritage Trail
- South Airdrie Path Network
- Clyde Walkway
- Forth and Clyde Canal (NCN 754)
- Cumbernauld to Glasgow
- Airdrie to Longriggend
- Shotts to Blackridge
- Carluke to Shotts
- Carron Valley Mountain Bike Trails



Previous Studies

The proposed active travel network will be developed not only with the Town and Community Hubs in mind but will incorporate key findings from previously conducted sustainable transport studies.

Key themes for the improvement of sustainable transport across the studies included a desire to:

- Provide greater priority to sustainable transport modes and improve the existing active travel network
- Improve integration between different modes of transport
- Provide transport interventions that will make it easier to travel around the area
- Provide transport interventions that will improve quality of life
- Improve safety and perceptions of safety
- Deliver improvements that enhance the towns as 'places' to live, work and visit

A wide range of interventions and improvement types have been proposed in order to realise the key themes for improvement identified from the previous studies including:

- Improved crossing facilities for people walking, wheeling and cycling; particularly at key journey origins or destinations such as rail stations
- Greater provision of street lighting in existing underpasses and other areas on the active travel network where lighting is currently considered poor
- Undertake a Council-wide signage and wayfinding review to identify gaps in the network, developing a consistent strategy for signage and improving route navigation and promotion
- Greater provision of cycle parking, cycle hire and bike maintenance schemes
- Identify and address known gaps in the active travel network to create more direct and desirable routes
- Work with rail operators to improve integration of cycling with rail journeys
- Improve active travel accessibility to workplaces and schools
- Introduce Integrated Travel Hubs at suitable locations
- Explore feasibility of developing cross-boundary links for active travel with other local authorities and partners



Future Network Vision

Strategic and wider active travel connections

A key aspiration of the Active Travel Strategy is to help provide safe, attractive and high-quality active travel infrastructure which helps facilitate people across North Lanarkshire to make everyday journeys by walking, wheeling or cycling. The key to achieving this strategy is creating and improving links not only within our towns but between our towns and beyond to the wider region. Providing these strategic connections will help ensure that our whole region is fully connected and help encourage people to travel by more active and sustainable means.

Working alongside key partners, we have assessed this wider active travel network to identify where there are currently gaps and where improvements could be made. Existing route options and active travel desire lines for these strategic destinations included routes between:

- | | | |
|---------------|----------------------------------|-----------------------------|
| ▪ Airdrie | ▪ Neighbouring local authorities | ▪ Strathclyde Business Park |
| ▪ Bellshill | ▪ Strathclyde Country Park | ▪ Gartcosh Business Park |
| ▪ Coatbridge | ▪ Drumpellier Country Park | ▪ Ravenscraig |
| ▪ Cumbernauld | ▪ Palacerigg Country Park | |
| ▪ Kilsyth | ▪ Eurocentral | |
| ▪ Motherwell | ▪ Biocity | |
| ▪ Shotts | ▪ Newhouse Industrial Estate | |
| ▪ Wishaw | | |

Assessing these wider and strategic active travel desire lines allowed us to form the basis of our proposed active travel networks, linking all of North Lanarkshire and beyond.

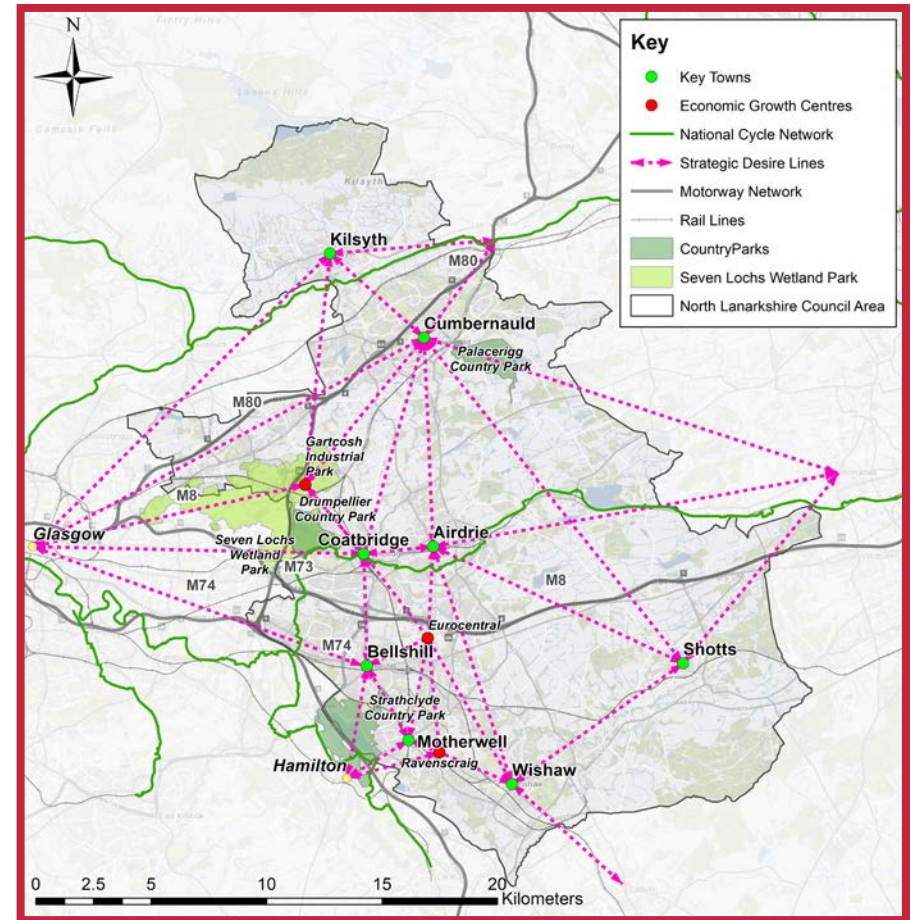

Figure 7 - Strategic Desire Lines Map

Active Travel Network Proposals

We are working to improve the existing network by increasing the availability of infrastructure to support walking, wheeling and cycling throughout our area. This will look to provide suitable infrastructure between key locations, workplaces and to the new Town and Community Hubs to encourage the uptake of active travel, especially for shorter and everyday journeys.

To introduce improved facilities, we are looking to provide a comprehensive network of shared use footways adjacent to the carriageway, where off-road routes are not feasible. This will enable people who want to walk, wheel or cycle for their everyday journeys to do so safely and segregated from general traffic. This network will be improved and implemented across North Lanarkshire to provide links between key destinations, support affordable and accessible travel options and benefit overall health and well-being.

In addition to providing new active travel facilities we will also seek to utilise and tie into our existing network to create a wide range of connections. This will include linking into our Country Parks path network which will further connections and allow users to travel away from the carriageway.

The future of the network we envisage will consist of:

1. **A Strategic Active Travel Network**, providing links to key destinations
2. **A Local Neighbourhood Active Travel Network**, which will be centred around the Town and Community Hubs
3. **A Connecting Active Travel Network**, to link in with existing paths and wider routes in our area.

Delivery of active travel infrastructure will, in many locations, require the reallocation of existing road space from general traffic to active travel modes. This reallocation could include measures such as footway and cycleway creation, and the narrowing or in some cases the removal of road lanes, on-street parking and loading bays. Decisions on road space reallocation will take into consideration all transport modes but will prioritise sustainable modes in keeping with the National Transport Strategy and Sustainable Transport Hierarchy.



Depending on local conditions, alternative solutions may be appropriate for different routes. Local factors will determine whether it is more appropriate for shared use infrastructure to be placed alongside or remote from the main road corridors.

The diagrams on the right show illustrations of what the proposed shared use walking, wheeling and cycling facilities may look like both alongside and away from the road carriageway. Below the images the preferred width for such shared use paths are shown along with the required widths for buffers between the path and road carriageways.

While shared use facilities alongside main arterial road corridors are a key feature of our everyday cycle network, off-road and remote path networks away from main roads also have a very important part to play for both functional and leisure journeys, connecting communities to key destinations. North Lanarkshire currently has a wide range of green access networks linking Country Parks, canals, heritage trails, river walkways and many more important outdoor assets. Aspirations for further off-road green access networks are outlined in Glasgow and Clyde Valley Green Network's Green Network Blueprint.

Further details of design standards and the required path and buffer widths for shared use facilities both alongside and remote from the carriageway area are provided in Appendix B. Further guidance on the construction of these facilities has been taken from Transport Scotland's Cycling by Design guidance and is provided in Appendix C.

Adjacent to carriageway

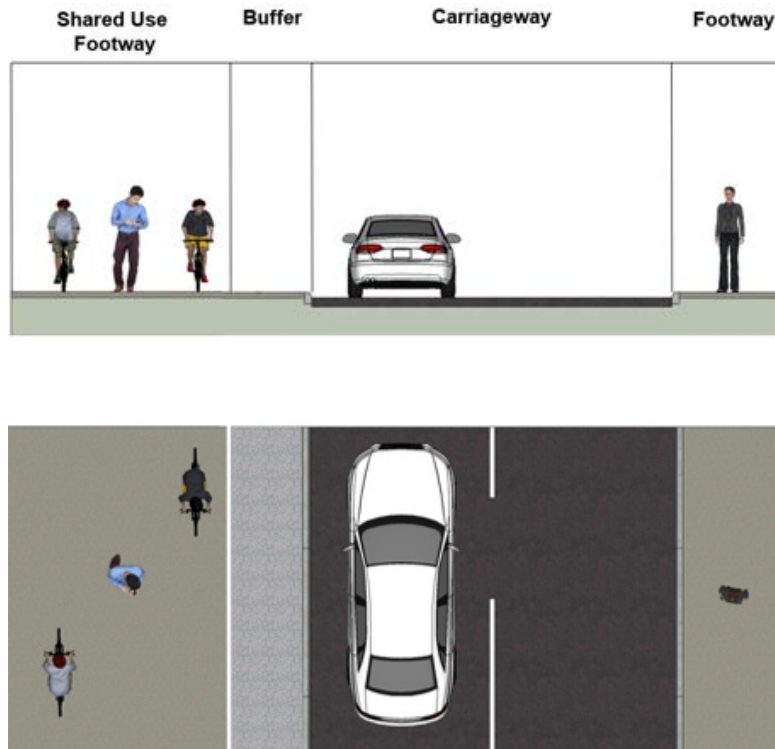

Speed Limit	Path	Buffer	Total Width
30mph	3.0m (4.0m*)	0.5m	3.5m (4.5m*)
40mph	3.3m	1.2m	4.5m
50mph +	3.8m	1.2m	5.0m

*High Amenity Areas

Remote from carriageway



Provision	Path Width
Absolute Minimum	2.5m
Desirable Minimum	3.0m
Preferred	3.5m (4.0m*)

*High Amenity Areas

Figure 8 - Adjacent to carriageway cross section

Figure 9 - Remote from carriageway cross section

Proposed Strategic, Local Neighbourhood and Connecting Networks

The proposed Active Travel Network will include the following:

The Strategic Active Travel Network will connect our key towns, providing direct, high-quality active travel links along main arterial routes that provide an attractive and sustainable travel option between our key towns. The network will provide safe and attractive shared use walking, wheeling and cycling links that have a buffer to separate them from main roads. Many of the key existing active travel links in North Lanarkshire such as the National Cycle Network would form part of the Strategic Active Travel Network. The improvement and promotion of these strategic routes will help demonstrate how even those wider journeys between towns can be achieved through more active and sustainable modes of travel. This could provide new opportunities for those with limited access to other modes of transport.

The Local Neighbourhood Active Travel Network will provide vital local connections within our towns and direct links to our wider connecting routes. These routes will link key local destinations, town centres, transport hubs and provide active travel links to local areas of employment, education, services and training. These links will largely consist of shared use facilities similar to the Strategic Active Travel Network but will utilise a greater number of off-road paths and local links. Most importantly these routes will link to our proposed Town and Community Hubs; around which further local improvements such as traffic speed reduction, traffic calming, improved crossing facilities, accessibility improvements and other dedicated walking, wheeling and cycling facilities will be introduced.

The Connecting Active Travel Networks will also be developed in locations where there are opportunities to develop key active travel routes that are outwith the proposed Strategic or Local Neighbourhood Active Travel Network proposals. These routes could feature on-road cycling on quiet rural roads or seek to improve existing shared use facilities along routes which may be utilised more for recreational cycling rather than everyday use.

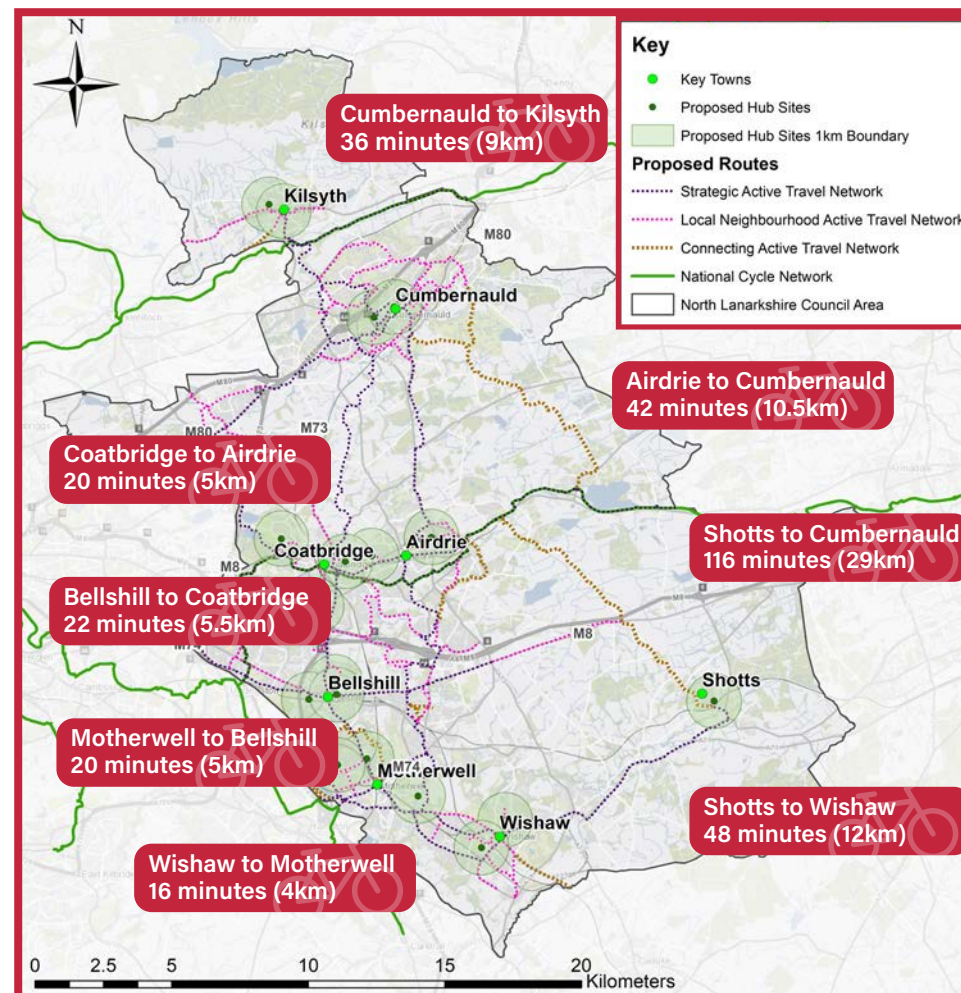

Figure 10 - Proposed Strategic and Local Neighbourhood Network with Cycle journey times

A more detailed map of the proposed Strategic and Local Neighbourhood Active Travel Network routes has been provided in Appendix D. All maps provided in this document are available to view and download from the North Lanarkshire Council website.

Partner and third party active travel networks

With our proposals for Strategic, Local Neighbourhood and Connecting Active Travel Networks in place, we will also work with key partners and third parties to explore areas where further improvements can be made.

Close and collaborative working alongside these key partners is an important factor for success in delivering an integrated and far-reaching active travel network both across North Lanarkshire and beyond our Council area boundary.

The map to the right shows where previous aspirational active travel routes have been identified by partners or through previous studies. This strategy has taken cognisance of existing and proposed off-road routes within North Lanarkshire to develop the overall network and provide wider and local connections for the local population.

We will engage with key partners to deliver these routes and networks where appropriate, including contributing to proposals and aspirations for the following:

- National Cycle Network
- Central Scotland Green Network
- Glasgow and Clyde Valley Green Strategic Access Network
- Routes associated with the Clydeplan
- Northern Corridor Community Volunteers identified opportunity routes

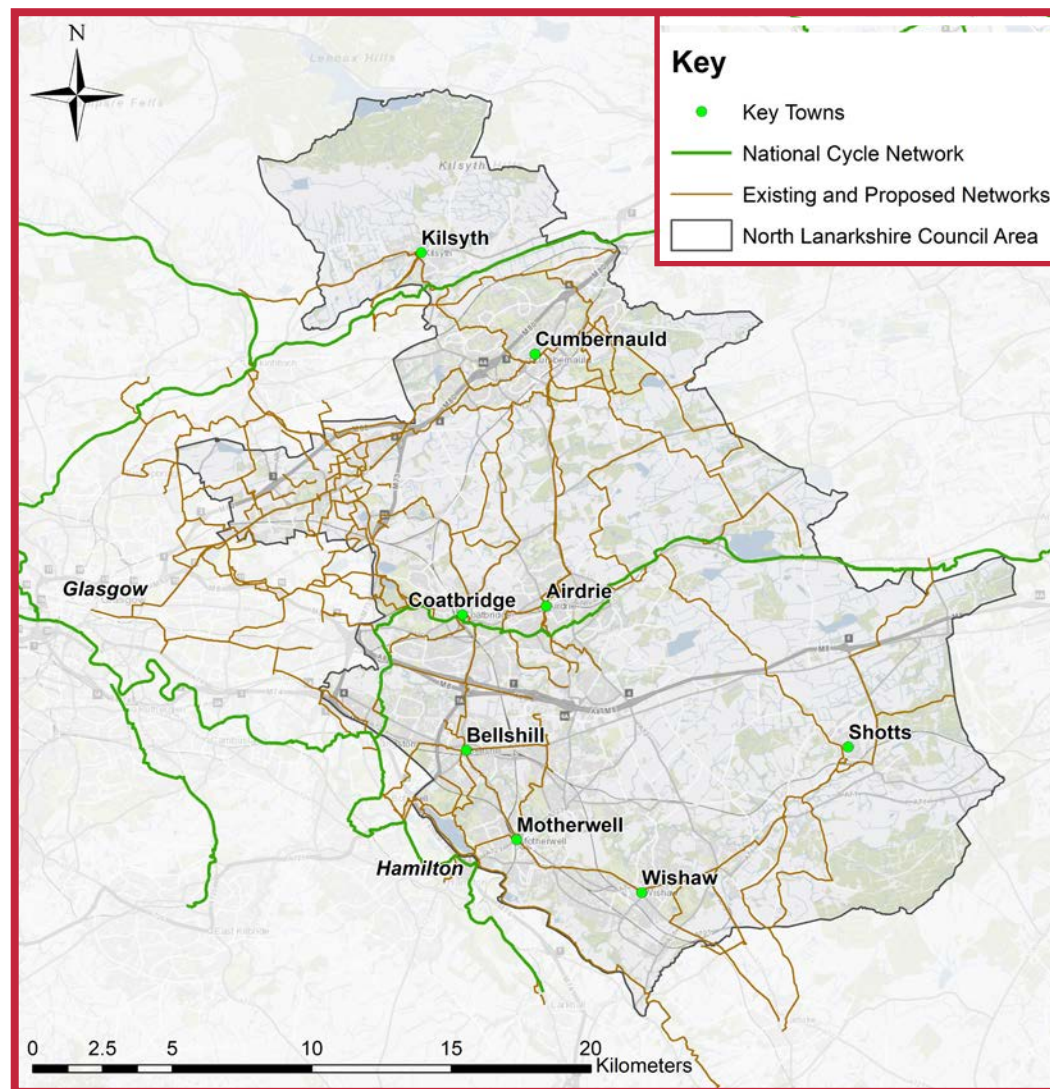

Figure 11 - Partner and Third Party Networks Map

Proposed improvements around Town and Community Hubs

Providing links between hubs and other key local destinations will provide the greatest potential for encouraging greater uptake of active travel in our area. Our Town and Community Hubs and the surrounding neighbourhood areas will become key focus areas for improvements to walking, wheeling and cycling facilities. The promotion of dedicated Active Travel Hubs around these facilities will be explored with the potential to facilitate programmes such as the provision of e-bikes, bike libraries, cycle training and other behaviour change activities. To support our Town and Community Hubs we will introduce:

Shared footways to each of the Town and Community Hubs to enable users to get there easily and safely



20mph zones and adequate traffic calming to support those wishing to cycle



Cycle parking facilities at each of the Town and Community Hubs allowing bikes to be stored and secured at each site



Accessibility enhancements to promote walking, wheeling and cycling opportunities



Action Plan

The Action Plan outlines the active travel networks we propose to introduce across our area along with the additional associated measures we are aiming to undertake for the improvement of active travel provision and its uptake across North Lanarkshire.

The actions have been divided into:

- **Community Hub Improvements** - local improvements to the areas surrounding the new Town and Community Hubs; alongside creating dedicated routes to link the hubs to town centres and key transport links
- **Strategic Active Travel Network Routes** - routes which are along main arterial routes and will link key destinations
- **Local Neighbourhood and Connecting Active Travel Network Routes** - links to local destinations such as Town Centres, Town and Community Hubs, local transport links, local amenities, education and employment
- **Other Actions** - Complementary measures that will help to promote and encourage walking, wheeling and cycling for everyday travel across our area and for the overall improvement of our active travel network

Each action has have been assigned a priority ranking of High, Medium or Low. Higher priority interventions are considered as those to have the greatest benefit for the widest number of users and should be prioritised for implementation before other priority interventions. These high priority routes could have the potential to open up wider links with other existing or proposed active travel routes. Lower priority routes might not provide the same network connections but could be considered important for leisure trips.

For many of the actions other local authorities and organisations will be involved in the development and delivery of these actions. The Action Plan identifies some key delivery partners for each action, however as these actions develop and our taken forward a more detailed list of delivery partners and local groups will be developed for each action. These partners could include community councils, community groups, schools etc.

A full list of the actions we propose to undertake has been provided in Appendix E.



Appendix A - Policy and Strategy Context

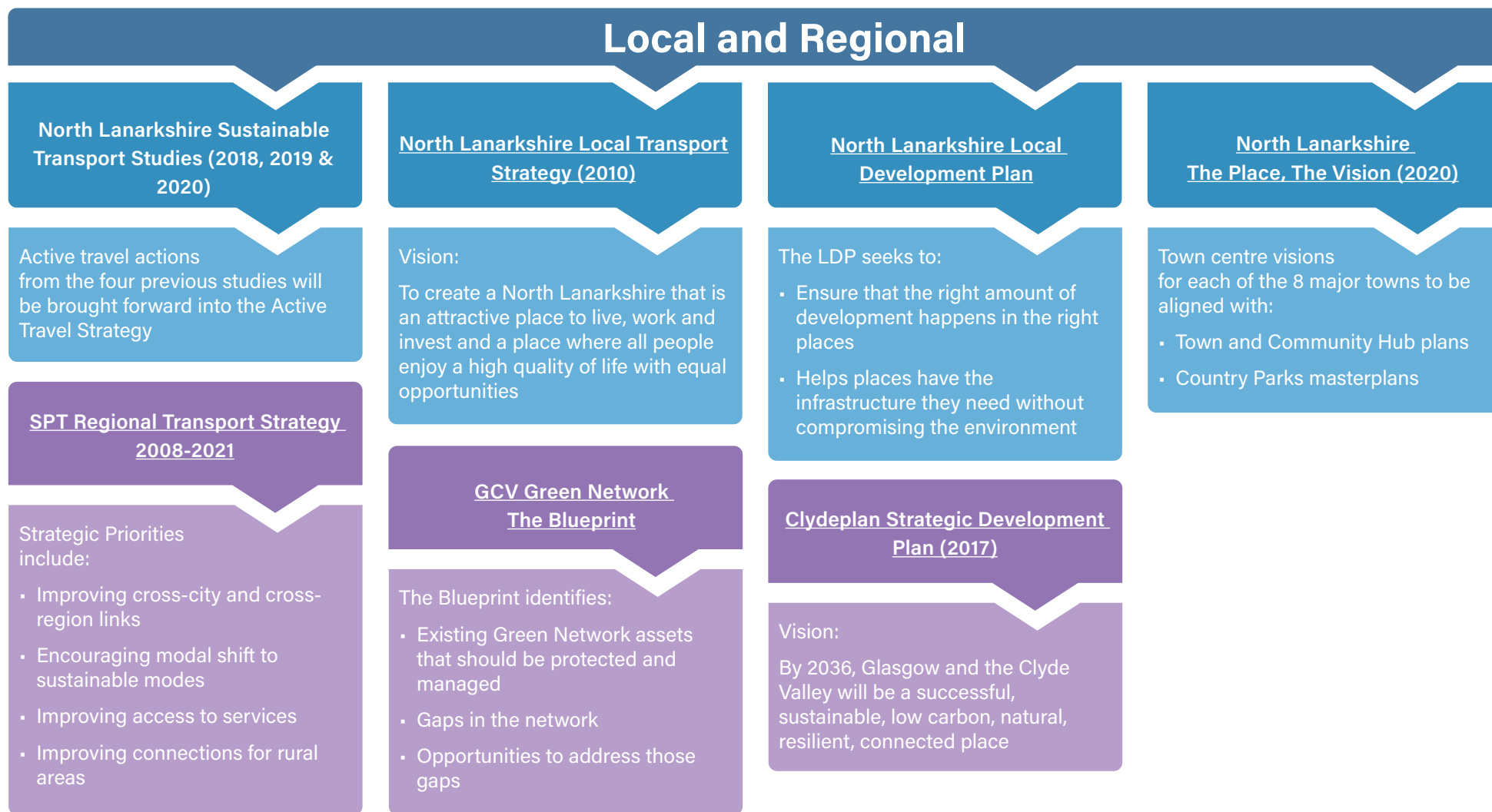

National

Transport (Scotland) Act (2019)

Provides new powers for Councils to improve sustainable transport including:

- Greater control of local bus services
- Enhanced partnership working arrangements
- Enforcement of Low Emission Zones

Strategic Transport Projects Review 2

Strategic review to inform Scottish Ministers of transport investment priorities over the next 20 years to 2042

Let's Get Scotland Walking - The National Walking Strategy (2014)

Aims:

- To create a culture of walking
- To provide better quality walking environments
- To ensure easy, convenient and independent mobility for all

National Planning Framework

National developments in the current National Planning Framework (NPF3) include a long distance cycling and walking network

Cycling Action Plan for Scotland (2017)

Purpose:

To develop a robust set of actions that will help to achieve a vision of 10% of everyday journeys to be made by bike, by 2020

Climate Change Plan 2018 - 2032 (2020 Update)

Sets out the Scottish Government's pathway to reduce Scotland's emissions of all greenhouse gases to net zero by 2045 as set out by the Climate Change Act 2019

National Transport Strategy 2 (2020)

Sets out a sustainable transport system vision that:

- Reduces inequalities
- Takes climate action
- Delivers inclusive economic growth
- Improves health and well-being

Infrastructure Commission for Scotland Key Findings and Delivery Report (2020)

Focuses on three core long-term outcomes:

- Inclusive economic growth
- Tackling the global climate emergency
- Building sustainable places

Appendix B - Active Travel Design Standards

Remote from carriageway paths should be considered first to the design standards outlined below however, where these are not suitable then shared use footways alongside road carriageways will be constructed based upon the widths in the tables below.

Preferred provision should be aimed for in all cases, however desirable and absolute minimums can be acceptable where space is limited. The widths shown are to meet North Lanarkshire Council's internal design standards.

For more detailed guidance on the development of improved active travel infrastructure, please refer to:

- [Cycling by Design](#)
- [The National Roads Development Guide](#)
- [The Design Manual for Roads and Bridges](#)
- [The Traffic Signs Regulations and General Directions](#)
- [The Traffic Signs Manual](#)

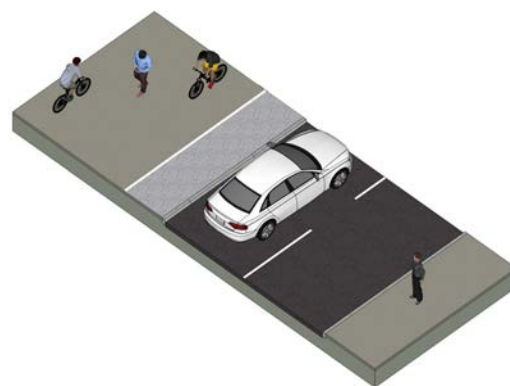
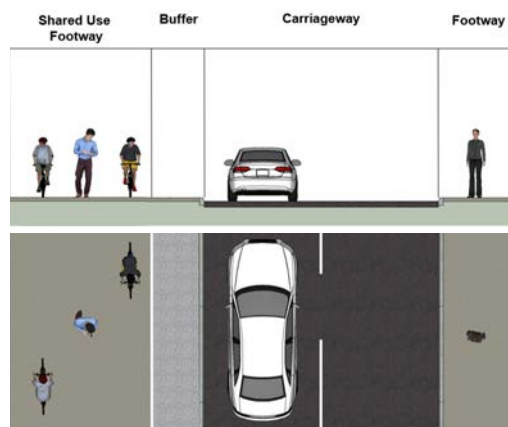

Speed Limit	Absolute Minimum			Desirable Minimum			Preferred Provision		
	Path	Buffer	Total Width	Path	Buffer	Total Width	Path	Buffer	Total Width
30mph	2.0m	0.5m	2.5m	2.5m	0.5m	3.0m	3.0m (4.0m*)	0.5m	3.5m (4.5m*)
40mph	2.0m	1.2m	3.2m	2.8m	1.2m	4.0m	3.3m	1.2m	4.5m
50mph +	2.3m	1.2m	3.5m	3.3m	1.2m	4.5m	3.8m	1.2m	5.0m

*High Amenity Areas

Adjacent to carriageway



Provision	Path Width
Absolute Minimum	2.5m
Desirable Minimum	3.0m
Preferred	3.5m (4.0m*)

*High Amenity Areas

Remote from carriageway

Appendix C - Construction Information

Construction information and depths for new active travel infrastructure will follow [Cycling by Design Standards](#) as outlined below.

Typical Pavement Construction - Urban

Construction Type	Pavement	Layer Details
Flexible	Surface Course	30mm Hot Rolled Asphalt (CI 910)
	Binder	50mm Dense Asphalt Concrete (CI 906)
	Sub-base	150mm Type 1 granular material (CI 803)
Rigid	Surface Course	40mm Granolithic Concrete (CI 1106)
	Base	75mm 25/37.5 Concrete (CI 1704)
	Sub-base	150mm Type 1 granular material (CI 803)
Surface Course	Surface Course	200 x 100 x 65mm precast Rectangular Concrete Block Paving (CI 1107) or Clay Pavers (CI 1108)
	Base	40 +/- 10mm bedding layer of Sharp Sand or Crushed Rock Fines
	Sub-base	150mm Type 1 granular material (CI 803)

Typical Pavement Construction - Rural

Construction Type	Pavement	Layer Details
Flexible Surfacing	Surface Course	30mm Hot Rolled Asphalt (CI 910) or 30mm Close Graded Asphalt Concrete (CI 912)
	Binder	40mm Dense Asphalt Concrete (CI 906)
	Sub-base	200mm Type 1 granular material (CI 803)
Flexible Surfacing	Surface Course	Combined surface course and binder, 60mm Close Graded Asphalt Concrete (CI 912)
	Sub-base	200mm Type 1 granular material (CI 803)
Unbound Surfacing	Running Surface	75mm binding material (CI 920)
	Sub-base	150mm Type 1 granular material (CI 803)

Typical Construction - Cycleway adjacent to kerbed carriageway

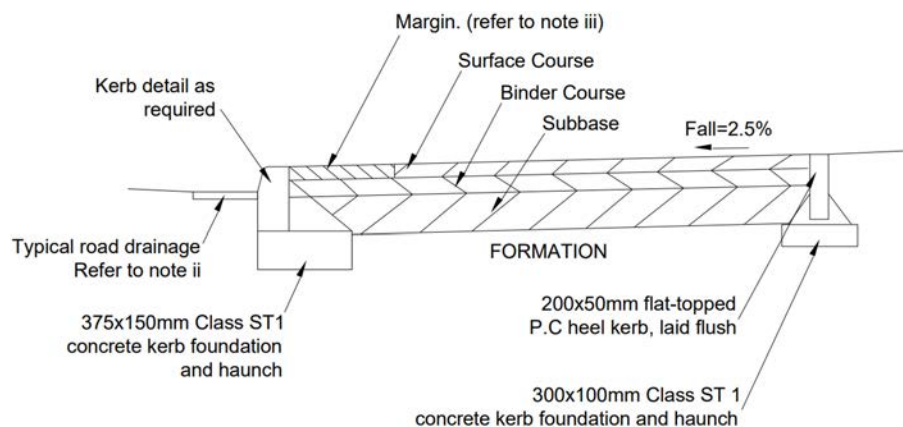

Typical Construction - Rural cycleway adjacent to carriageway (unkerbed)

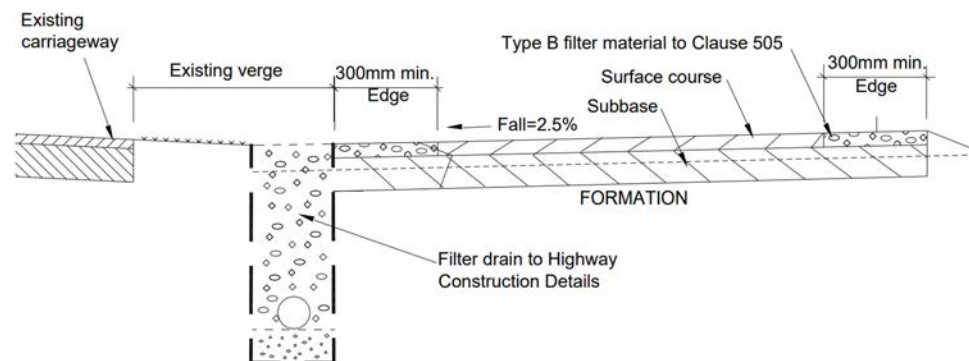

Typical Construction - Rural cyclepath remote from carriageway

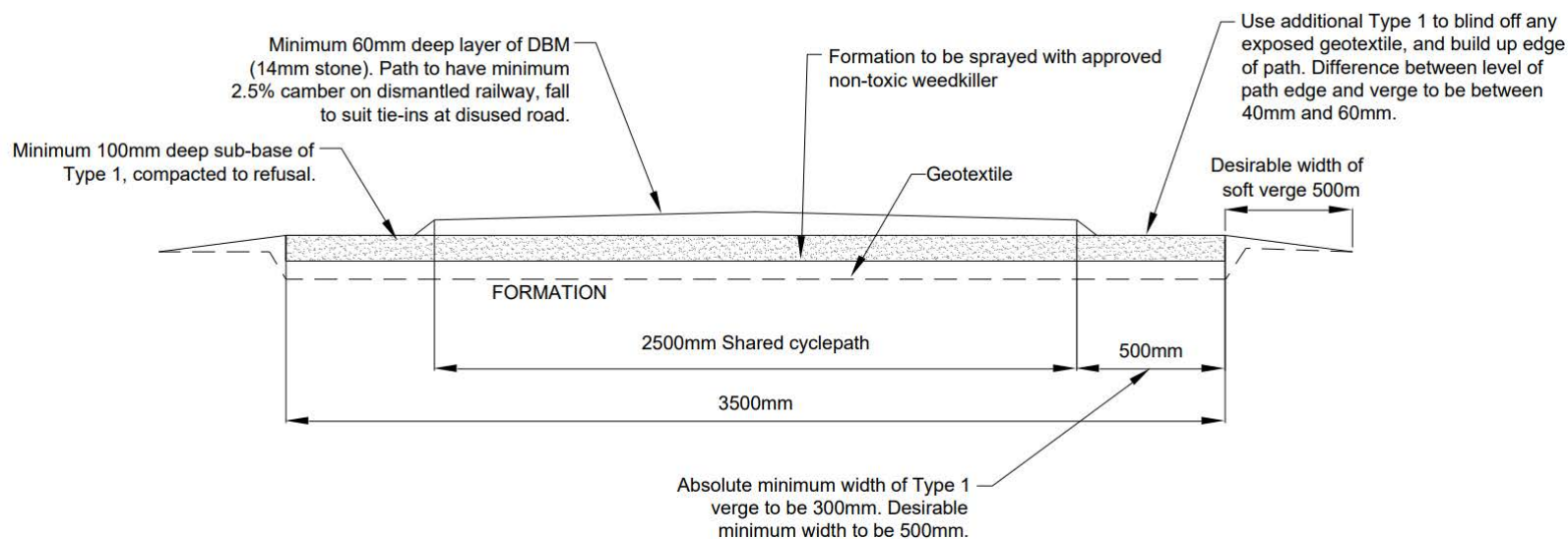

Appendix D - Proposed Network

Key

- Key Towns
- Proposed Hub Sites
- Proposed Hub Sites 1km Boundary

Proposed Routes

- Strategic Active Travel Network
- Local Neighbourhood Active Travel Network
- Connecting Active Travel Network
- National Cycle Network
- North Lanarkshire Council Area

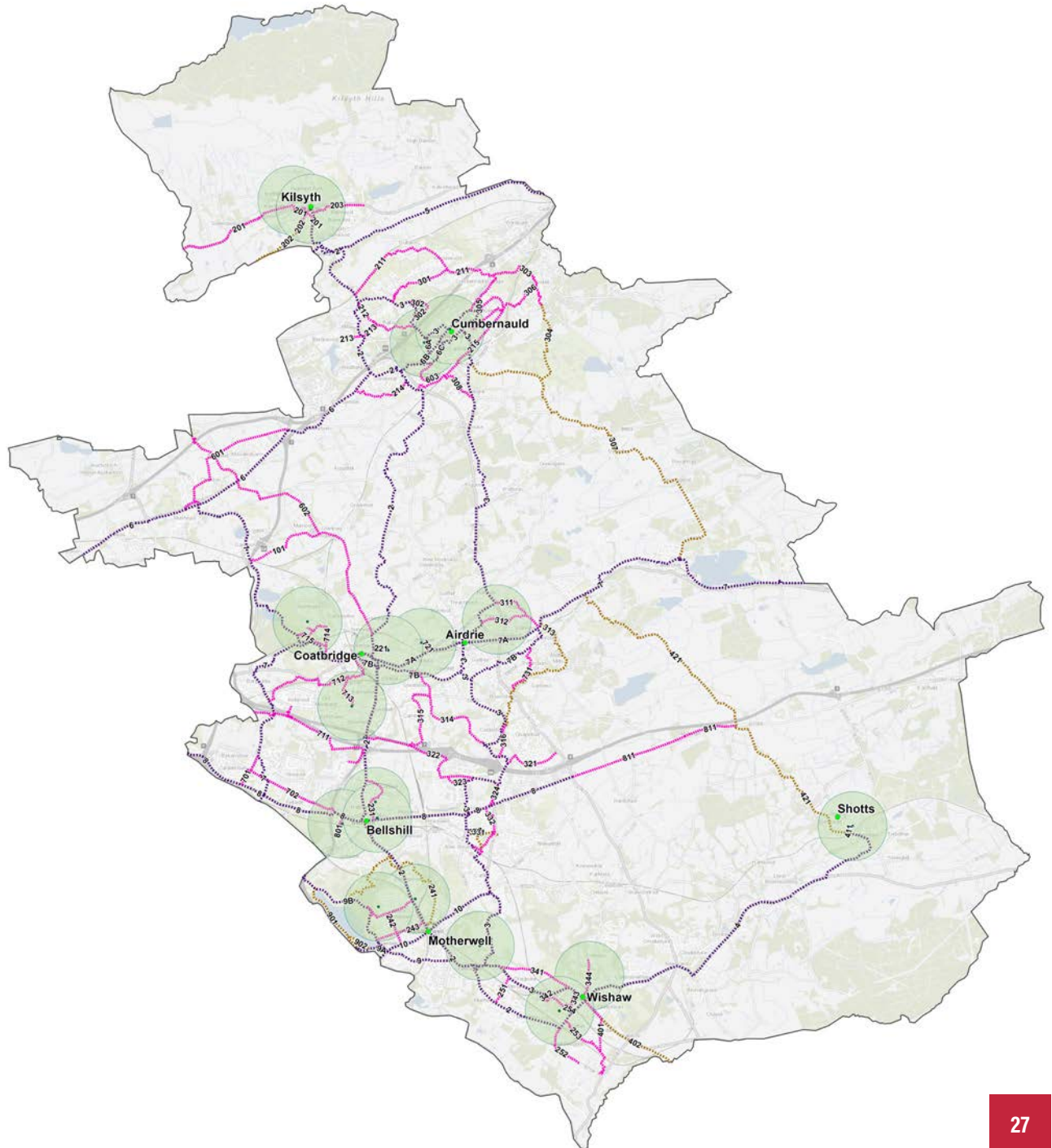

Appendix E - Action Plan

The Action Plan outlines the active travel routes we propose to introduce across our area along with the additional associated measures we are aiming to undertake for the overall improvement of active travel provision and uptake across North Lanarkshire. The actions in the plan relate to Community Hub Improvements and the Strategic, Local Neighbourhood and Connecting Active Travel Networks and along with the additional measures have been assigned a priority ranking of High, Medium or Low. Higher priority interventions are considered as those to have the greatest benefit for the widest number of users and should be prioritised for implementation before other priority interventions. These high priority routes could have the potential to open up wider links with other existing or proposed active travel routes. Lower priority routes might not provide the same network connections but could be considered important for leisure trips.

AP Ref	Action Type	Route Ref	Title	Description	Priority	Other Key Partners
1.0	Community Hub Improvements					
1.1	Community Hub Improvement	H1	Airdrie Hubs Neighbourhood Network	Local area review around hubs, identification of improvements to active travel infrastructure, shared use footways, road crossings, accessibility, traffic calming, cycle parking and cycle friendly neighbourhood improvements. Creation of dedicated routes between hubs, town centres and key transport interchanges. Improvement of existing facilities where they currently exist.	High	
1.2	Community Hub Improvement	H2	Bellshill Hubs Neighbourhood Network		High	
1.3	Community Hub Improvement	H3	Coatbridge Hubs Neighbourhood Network		High	
1.4	Community Hub Improvement	H4	Cumbernauld Hubs Neighbourhood Network		High	
1.5	Community Hub Improvement	H5	Kilsyth Hubs Neighbourhood Network		High	
1.6	Community Hub Improvement	H6	Motherwell Hubs Neighbourhood Network		High	
1.7	Community Hub Improvement	H7	Shotts Hubs Neighbourhood Network		High	
1.8	Community Hub Improvement	H8	Wishaw Hubs Neighbourhood Network		High	

AP Ref	Action Type	Route Ref	Title	Description	Priority	Other Key Partners
2.0	Strategic Active Travel Network					
2.1	Strategic Network Route	SNR 1	North-South Corridor from Coatbridge to Muirend via Drumpellier Country Park	Strategic shared use walking and cycling paths along main arterial routes and linking strategic destinations. Off-carriageway routes may be either adjacent to or away from the carriageway. See Appendix B for desired shared use path and buffer widths. Improvement of existing facilities where they currently exist.	Medium	Drumpellier Country Park Seven Lochs Wetland Park
2.2	Strategic Network Route	SNR 2	Core North-South Corridor from Kilsyth to Wishaw via Croy, Broadwood, Condorrat, Coatbridge, Bellshill and Motherwell		High	East Dunbartonshire Council Falkirk Council Sustrans Scottish Canals
2.3	Strategic Network Route	SNR 3	North-South Corridor from Croy to Wishaw via Cumbernauld Circular, Airdrie, Calderbank, Eurocentral, Holytown, Carfin, Ravenscraig and Shieldmuir via A721		High	East Airdrie Link Road Team
2.4	Strategic Network Route	SNR 4	Wishaw to Shotts via Newmains		Medium	
2.5	Strategic Network Route	SNR 5	Forth and Clyde Canal (NCN754) between Haggs and Auchinstarry		High	
2.6	Strategic Network Route	SNR 6	East-West Corridor between Stepps and Condorrat via the A80 and Dalshannon		High	Glasgow City Council
2.7	Strategic Network Route	SNR 7	Uddingston to Caldercruix via Coatbridge and Airdrie utilising both NCN75 and A89 route options		High	Sustrans West Lothian Council South Lanarkshire Council Drumpellier Country Park
2.8	Strategic Network Route	SNR 8	East-West Corridor between A74 Glasgow border and Newhouse via Bellshill and Holytown		High	Glasgow City Council

AP Ref	Action Type	Route Ref	Title	Description	Priority	Other Key Partners
2.9	Strategic Network Route	SNR 9	Airbles Road to South Lanarkshire at Strathclyde Country Park and to Bothwell	Strategic shared use walking and cycling paths along main arterial routes and linking strategic destinations. Off-carriageway routes may be either adjacent to or away from the carriageway. See Appendix B for desired shared use path and buffer widths. Improvement of existing facilities where they currently exist.	High	South Lanarkshire Council
2.10	Strategic Network Route	SNR 10	A723 between South Lanarkshire boundary and Carfin via Motherwell		High	South Lanarkshire Council
3.0	Local Neighbourhood and Connecting Active Travel Networks					
3.1	Local Neighbourhood Route	LNR 101	Gartcosh to Garnqueen	Generally off-carriageway walking and cycling routes incorporating both shared use paths in urban locations and on-carriageway routes in quieter rural settings. Incorporates Local Neighbourhood Routes which connect key local destinations, transport interchanges, schools and proposed town and community hubs. Also incorporates the Connecting Networks which are often more rural or recreational in nature and of less strategic everyday value. Improvement of existing facilities where they currently exist.	Low	
3.2	Local Neighbourhood Route	LNR 201	Kilsyth town centre to Queenzieburn including Airdrie Road		High	East Dunbartonshire Council
3.3	Local Neighbourhood Route	LNR 202	Kilsyth town centre to River Kelvin via Garrel Burn		Low	East Dunbartonshire Council
3.4	Local Neighbourhood Route	LNR 203	Kilsyth town centre to Colzium		Low	
3.5	Local Neighbourhood Route	LNR 211	Croy to Cumbernauld Village via Dullatur and Carrickstone		Low	
3.6	Local Neighbourhood Route	LNR 212	Balloch Links		Medium	
3.7	Local Neighbourhood Route	LNR 213	Balloch to Broadwood		Medium	
3.8	Local Neighbourhood Route	LNR 214	Condorrat Link		Low	
3.9	Local Neighbourhood Route	LNR 215	Condorrat to Kildrum via rail stations		Medium	
3.10	Local Neighbourhood Route	LNR 221	Coatbridge High School Link		High	
3.11	Local Neighbourhood Route	LNR 231	Hattonrig Link		High	
3.12	Local Neighbourhood Route	LNR 241	Motherwell Greenlink to Strathclyde Country Park		Low	

AP Ref	Action Type	Route Ref	Title	Description	Priority	Other Key Partners
3.13	Local Neighbourhood Route	LNR 242	North Motherwell Links	Generally off-carriageway walking and cycling routes incorporating both shared use paths in urban locations and on-carriageway routes in quieter rural settings. Incorporates Local Neighbourhood Routes which connect key local destinations, transport interchanges, schools and proposed town and community hubs. Also incorporates the Connecting Networks which are often more rural or recreational in nature and of less strategic everyday value. Improvement of existing facilities where they currently exist.	High	Strathclyde Country Park
3.14	Local Neighbourhood Route	LNR 243	Motherwell Station to Strathclyde Country Park via Ladywell Road		Medium	Network Rail Strathclyde Country Park
3.15	Local Neighbourhood Route	LNR 251	Shieldmuir Link		Medium	
3.16	Local Neighbourhood Route	LNR 252	Gowkthrapple Link		Low	
3.17	Local Neighbourhood Route	LNR 253	Pather Link		Low	
3.18	Local Neighbourhood Route	LNR 254	Wishaw Sports Centre Link		High	
3.19	Local Neighbourhood Route	LNR 301	Balloch to Carrickstone		Low	
3.20	Local Neighbourhood Route	LNR 302	Craighalbert Road and Eastfield Link		Low	
3.21	Local Neighbourhood Route	LNR 303	Cumbernauld to Abronhill via Cumbernauld Village		Low	
3.22	Local Neighbourhood Route	LNR 304	Abronhill to Palacerigg		Low	Palacerigg Country Park
3.23	Local Neighbourhood Route	LNR 305	Cumbernauld to Cumbernauld Village via Kildrum		Low	
3.24	Local Neighbourhood Route	LNR 306	Cumbernauld to Abronhill via Kildrum		Low	
3.25	Connecting Network Route	CNR 307	Caldercruix to Cumbernauld via Lonriggend		Low	
3.26	Local Neighbourhood Route	LNR 308	Greenfaulds Station to Luggiebank		Low	
3.27	Local Neighbourhood Route	LNR 311	East Airdrie Link Road Cycle Route - Clarkston		Medium	East Airdrie Link Road Team
3.28	Local Neighbourhood Route	LNR 312	Rawyards Links		High	
3.29	Connecting Network Route	CNR 313	North Calder Heritage Trail Path Network	Low		
3.30	Local Neighbourhood Route	LNR 314	Monkland Canal	Medium		

AP Ref	Action Type	Route Ref	Title	Description	Priority	Other Key Partners
3.31	Connecting Network Route	CNR 315	Sikeside to M8 Cycle Route via Carnbroe	Generally off-carriageway walking and cycling routes incorporating both shared use paths in urban locations and on-carriageway routes in quieter rural settings. Incorporates Local Neighbourhood Routes which connect key local destinations, transport interchanges, schools and proposed town and community hubs. Also incorporates the Connecting Networks which are often more rural or recreational in nature and of less strategic everyday value. Improvement of existing facilities where they currently exist.	Low	Transport Scotland
3.32	Local Neighbourhood Route	LNR 316	East Airdrie Link Road - Calderbank		Medium	East Airdrie Link Road Team
3.33	Local Neighbourhood Route	LNR 321	Lancaster Avenue, Chapelhall		Low	
3.34	Local Neighbourhood Route	LNR 322	M8 Cycle Path - A725 to Eurocentral		Medium	Transport Scotland
3.35	Local Neighbourhood Route	LNR 323	Eurocentral Coddington Crescent Links		Medium	
3.36	Local Neighbourhood Route	LNR 324	Bo'ness Road, Holytown		Low	
3.37	Connecting Network Route	CNR 331	New Stevenson Links (A723 Footbridge)		Low	
3.38	Local Neighbourhood Route	LNR 332	New Stevenson Links (Holytown to Holytown Station)		Medium	
3.39	Connecting Network Route	CNR 333	New Stevenson Links (Park Path Network)		Low	
3.40	Local Neighbourhood Route	LNR 341	Wishaw Link Path		Low	Green Action Trust
3.41	Local Neighbourhood Route	LNR 342	Wishaw Hospital Link		High	
3.42	Local Neighbourhood Route	LNR 343	Wishaw Station Link		High	
3.43	Local Neighbourhood Route	LNR 344	St Aiden's High School Link		High	
3.44	Local Neighbourhood Route	LNR 401	Overtown Link		Low	
3.45	Connecting Network Route	CNR 402	Wishaw to Law Link		Low	South Lanarkshire Council
3.46	Local Neighbourhood Route	LNR 411	Calderhead High School Link		High	
3.47	Connecting Network Route	CNR 421	Shotts to Plains via Salsburgh		Low	
3.48	Local Neighbourhood Route	LNR 601	Muirhead to Moodiesburn via Chryston		Low	

AP Ref	Action Type	Route Ref	Title	Description	Priority	Other Key Partners
3.49	Local Neighbourhood Route	LNR 602	Strathkelvin Railway Path to Coatbridge	Generally off-carriageway walking and cycling routes incorporating both shared use paths in urban locations and on-carriageway routes in quieter rural settings. Incorporates Local Neighbourhood Routes which connect key local destinations, transport interchanges, schools and proposed town and community hubs. Also incorporates the Connecting Networks which are often more rural or recreational in nature and of less strategic everyday value. Improvement of existing facilities where they currently exist.	Low	East Dunbartonshire Council
3.50	Local Neighbourhood Route	LNR 603	Greenfaulds Road		Low	
3.51	Local Neighbourhood Route	LNR 701	Viewpark and Tannochside Links (Old Edinburgh Road)		Low	
3.52	Local Neighbourhood Route	LNR 702	Viewpark and Tannochside Links (Holmbræ Road)		Low	
3.53	Local Neighbourhood Route	LNR 711	M8 Cycle Path Ballieston to Strathclyde Business Park		Medium	
3.54	Local Neighbourhood Route	LNR 712	Coatbridge to Kirkwood via Luggie Glen		Low	
3.55	Local Neighbourhood Route	LNR 713	St Andrew's High School to Coatbridge		High	
3.56	Local Neighbourhood Route	LNR 714	St Ambrose High School to Blairhill Links		High	Drumpellier Country Park Seven Lochs Wetlands
3.57	Local Neighbourhood Route	LNR 715	Drumpellier Link		Low	Drumpellier Country Park Seven Lochs Wetlands
3.58	Local Neighbourhood Route	LNR 721	Monklands Hospital Link		High	
3.59	Local Neighbourhood Route	LNR 731	East Airdrie Link Road Cycle Route - Brownsburn to Craigneuk via Petersburn		Medium	East Airdrie Link Road Team
3.60	Local Neighbourhood Route	LNR 801	Cardinal Newman High School Link		High	
3.61	Local Neighbourhood Route	LNR 811	Newhouse to Salsburgh		Medium	
3.62	Connecting Network Route	CNR 901	Strathclyde Loch West (on-road)		Low	South Lanarkshire Council Strathclyde Country Park
3.63	Connecting Network Route	CNR 902	Strathclyde Loch West (lochside)		Low	South Lanarkshire Council Strathclyde Country Park

AP Ref	Action Type	Route Ref	Title	Description	Priority	Other Key Partners
4.0	Other Actions					
4.1	Other Actions	-	Continued Smarter Choices, Smarter Places (SCSP) Programme	Continued utilisation of the Scottish Government's SCSP programme and equivalent funding streams while available to deliver smarter measures and behaviour change programmes	High	Paths for All Living Streets
4.2	Other Actions	-	Cycle Training	Continued support of local cycle training, particularly in schools	Medium	Sustrans Local Schools
4.3	Other Actions	-	Promotion of Cycle Friendly Employer Award	Support and promotion of Cycling Scotland's Cycle Friendly Employer Award	Low	Cycling Scotland
4.4	Other Actions	-	Promotion of recreational walking and cycling routes	Continued promotion of key leisure routes across North Lanarkshire	Medium	Local Groups
4.5	Other Actions	-	Cycling Walking Safer Routes (CWSR) Programme	Continued utilisation of the CWSR Programme to improve local environments	High	
4.6	Other Actions	-	Cycle Parking Strategy	Authority wide review of cycle parking facilities and identification of recommendations for future improvements	Medium	
4.7	Other Actions	-	Active Travel Signage and Wayfinding Review and Strategy	Authority wide review of existing active travel signage and wayfinding and identification of recommendations for future	Medium	
4.8	Other Actions	-	Monitoring and Evaluation Strategy	Creation of a dedicated Monitoring and Evaluation Strategy for the Active Travel Strategy and Annual Review against pre-set targets	High	

AP Ref	Action Type	Route Ref	Title	Description	Priority	Other Key Partners
4.9	Other Actions	-	Review Existing Underpasses	Authority wide review of existing underpasses and identification of recommendations for future improvements	Medium	
4.10	Other Actions	-	Authority wide review of existing Advisory 20mph limits	Authority wide review of existing "Twenty's Plenty" advisory 20mph limits and creation of strategy following Transport Scotland's revised status of such measures	High	Transport Scotland Police Scotland
4.11	Other Actions	-	Integration of bikes and public transport review	Review of integration of bikes and public transport across North Lanarkshire, consultation with key public transport partners and development of a strategy for improvements	High	SPT ScotRail Network Rail Local Bus Providers
4.12	Other Actions	-	Road Safety Review	Review relevant accident statistics and direction of appropriate action where required	High	
4.13	Other Actions	-	Walking, Cycling and Horse-Riding Assessment and Review (WCHAR) to be undertaken on major development opportunities	Adoption of the WCHAR process for new development opportunities across North Lanarkshire	Medium	Local Developers
4.14	Other Actions	-	Green and off-road network maintenance strategy	Develop a maintenance strategy with partners for green network / remote from the carriageway routes	Medium	Green and off-road network partners
4.15	Other Actions	-	Embed Active Travel standards in Planning Process	Embed minimum standards of active travel provision and design for new developments within the Planning Process	High	Local Developers
4.16	Other Actions	-	Review of existing active travel infrastructure	Review existing provision for active travel and identify areas for required improvement works	High	Off-road network partners

This document can be made available in a range of languages and formats, including large print, braille, audio, electronic and accessible formats.

To make a request, please contact Corporate Communications on 01698 302527 or email: corporatecommunications@northlan.gov.uk

'S urrainn dhuinn an sgrìobhainn seo a chur ann an diofar chànanan agus chruthan, a' gabhail a-steach clò mòr, braille, cruth claisneachd agus cruthan dealanach agus ruigsinneach.

Gus iarrrtas a dhèanamh, cuir fios gu Conaltradh Corporra air 01698 302527 no cuir fios gu: corporatecommunications@northlan.gov.uk

本文档可以多种语言和格式提供, 包括大号字体、盲文、音频、电子和可访问格式。

如欲提出请求, 请致电01698 302527或发送电子邮件至:

corporatecommunications@northlan.gov.uk与企业传播部门 (Corporate Communications) 联系。

Ten dokument jest dostępny w różnych językach i formatach, w tym w formacie elektronicznym, dużą czcionką, w alfabecie Braille'a, w wersji audio i przystępnych formatach.

W celu złożenia zamówienia prosimy skontaktować się z Wydziałem Komunikacji Zewnętrznej telefonicznie na numer 01698 302527 lub na adres e-mail: corporatecommunications@northlan.gov.uk

لاریب، یئیی آپھچ یکی فورج ے ژب ل می ن ج، ے ہی تکی ساج یکی مہارف ل می (سٹ می راف) ول کش رواں ون اب زکی ای یئی گ زی واتس د ہی۔
- ل می ل م اش یھب ل می ل کش می یئی اس ر ل باق رواک ن رٹکی ل ا، وی ڈآ، (یئی اھکل کی فورج ے یی وہ ے رھب ے کی ل ے ک دارفا ان یی ان)
رپ ے ستپ س ای ل رکی ہطب ار ے س زنش یکی کی وی کم ٹی روپ راک رپ 01698 302527 یی ان اب رھم ے یی ارب ے کی ل ے ک ے ن رکی ت س اوخ رد
س: corporatecommunications@northlan.gov.uk یی ج یھب ل می ی

Produced by

NORTH LANARKSHIRE COUNCIL

Environmental Design and Engineering

Enterprise & Communities

2 Tryst Road

Cumbernauld

Glasgow, G67 1JW

t.

e.

NORTHLANARKSHIRE.GOV.UK



INVESTORS
IN PEOPLE

Accredited
Until 2021

